



INTERNATIONAL SNOWMOBILE RACING

1527 North Railroad Street Eagle River, WI 54521

262-335-2401

HILL CROSS 2021-22 VERIFICATION AND CONTROL

These GENERAL RULES apply to all types of ISR racing sanctions and all classes unless so noted. All participants, racers and crewmembers are required to be fully aware of these regulations and must abide by them.

The rules for competition are intended only as a guide for the conduct of the sport in a uniform manner from region to region.

Safety rules and guidelines contained herein are of utmost importance. All participants must be concerned with safety and be familiar with these rules and guidelines. However, ISR does not warrant, guarantee or ensure safety even if the rules are enforced and/or adhered to. Moreover, each participant in competition has the responsibility to assess the safety aspects of the facilities and conditions and must assume the risk of competition.

MANDATORY EMERGENCY VEHICLE

1. A properly licensed and equipped emergency vehicle (i.e. rescue vehicle or ambulance) must be at the race site to transport injured persons to an appropriate hospital. Said vehicle will be fully equipped to include items such as oxygen, first aid, burn equipment, splints, backboard and stretcher. This vehicle shall have all emergency equipment. **Contract arrangements must be made to have a transport situation ambulance on site if a transport is made. Many tracks are now using a track owned ambulance for on-site work. Many times, these vehicles are not certified for transport of patients on the highway. Arrangements must be made for a certified transport ambulance to make the actual patient transport. Racing must not be allowed without an ambulance on the grounds.**

RULE SUPPLEMENTS

1. Rule supplements, additions or corrections shall be announced on the official website. Upon such an announcement the rule changes become effective and enforceable.
2. Telephonic race rules conference calls will be followed up with an information letter to the affected affiliates.
3. After a rules meeting, any request to reconsider a new rule requires a majority vote of the rules committee to approve a revote. Then, a ¾ majority is also required to change the rule.

CLASS DIVISIONS

1. All class entries will not discriminate based on sex. Any qualified member may participate in the approved classes offered in any sanctioned event.
2. A snowmobile will be allowed to race in its respective displacement, or designated performance class, and any larger displacement or performance class, except as noted in specific sections.

REGISTRATION AND ENTRY

1. WAIVER FORMS ARE MANDATORY FOR ALL PERSONNEL IN SECURED AREAS (paddock, staging and track).
2. Driver must have registered at race headquarters and signed a waiver before any runs are made (practice or racing). No one, except officially entered drivers may ride or practice on any racecourse on the day of the event.
3. No refunds of entry or other fees will be made at sanctioned events after registration is closed, unless the event is cancelled or rescheduled by a ruling of the Race Director, after which time fees will be returned or advanced to the next event in the series.
4. Any competitor who pays for race entry or organization membership with a check or credit card is responsible for the payment of all charges should the bank or other institution fail to remit for whatever reason.
5. Drivers who fail to complete payment for entry fees are subject to discipline prescribed by the ISR affiliate. Drivers may be suspended for a period of one year from the date on which the debt is paid.
 - a. If the participant stops payment on check or credit card, participant gives up the right to protest or appeal until full payment is made.
 - b. Participants who pass NSF checks must pay entry and prescribed fees in full before the next race or within 30 days, whichever is sooner.
6. Insurance fees are not refundable.
7. Regional service charges or insurance surcharges are not considered part of entry fee maximums.
8. Gate admission fees for driver and crewmembers will be regulated on a regional basis.
9. The order of events will be regulated on a regional basis.
10. The maximum number of classes a driver can enter per day will be regulated on a regional basis.

11. Any class or event can be eliminated when there are less than two (2) official entries at the close of registration.
12. All participants in events must be fully familiar with the rules and regulations, plus such rules by Race Promoters that may be specifically applied to any event.

DRIVER AND SNOWMOBILE

1. A driver and his snowmobile (chassis and engine) shall be considered a unit and once the class has begun, neither will be substituted. If a driver qualified on a snowmobile, both must be in the same final event of the class and/or event.
2. Engine parts may be replaced during the event, except for the crankcase and crankshaft, which may not be replaced.

SPONSOR IDENTIFICATION

1. Anytime the sanctioning organization or sanctioned event has a sponsorship, all members and promoters must meet sponsorship requirements, if drivers' number system is not compromised.
2. Recommended size for any sponsor's required emblem should not exceed sixteen (16) square inches on the front and twenty-four (24) square inches on the back of the driver's uniform.

DRIVER IDENTIFICATION

1. There will be an automatic suspension for drivers who race under another driver's number.
2. All drivers will wear their issued bib or a facsimile thereof. Drivers will be required to keep the snowmobile numbers and drivers' body back numbers in a legible condition. Drivers must either wear a bib with their name and number for the event or their number built into the upper body outer garment worn during competition. Numbers are to be 8 inches high with a one-inch width. Name letters are to be 2 inches high with a 3/8" width.

SNOWMOBILE IDENTIFICATION

1. **Snowmobiles will have the appropriate number plate affixed to their race vehicle. Regional and affiliate rules may require background colors and contracting numbers for each class. ISR supports this requirement.**

PRE-RACE SAFETY INSPECTION

1. ANY ENTRY IS SUBJECT TO INSPECTION AT ANY TIME UPON REQUEST BY THE RACE DIRECTOR OR TECHNICAL DIRECTOR.
2. Pre-race safety inspections are mandatory at all races. Passing a pre-race safety inspection is no guarantee that a snowmobile complies with all rules for the event. Affiliates may allow prerace safety inspections to be conducted at the first race of a series and allow the sled to compete in subsequent events in the series without reinspection if on track records indicate no evidence crashes during competition.
3. Only snowmobiles having passed pre-race inspection will be allowed on the racetrack.
4. All aspects of modification are contingent on safety inspection by the Technical Director. The Technical Director may remove any snowmobile from competition that does not meet safety requirements.
5. Damaged or broken safety equipment (not including tether switch) not detected during a race is not grounds for disqualification after completion of that race unless black-flagged during the race in question.

MANDATORY TEARDOWN

1. Regardless of snowmobile equipment passing prior inspections, compliance with the rules must be made at the post-race inspection.
2. Once a snowmobile has completed registration to race it may be inspected at any time.
3. Tech Director will select the snowmobiles for mandatory teardown and inspection. Drivers will take their snowmobiles directly to Tech after completing the race. The snowmobile must remain in Tech until released by the Tech Director or a designated member of the Tech staff.
4. Driver and/or driver's mechanic will perform teardown to point required by the Technical Director.
5. Any driver not reporting to Tech or refusing teardown will be disqualified.
6. Inspected snowmobiles will not be reassembled by the inspection group.
7. Driver and/or driver's mechanic will be the only two (2) people allowed with the snowmobile in the inspection area.
8. The sanctioning organization assumes no responsibility for impounded snowmobiles.

SEALS

1. Drivers will allow the installation of a seal or seals on the engine and/or body of their racing snowmobiles. To change the seal, mutilate it or try to break it, or re-use it, during the weekend or event where it is installed without the consent of the Race Director, could result in the responsible driver being called before the disciplinary committee for strict discipline. Accidental breakage of the seal must be reported to the Race Director immediately.

PROTESTS

1. All formal protests must be made in writing, by a driver, in competition at the event, from the class in question, on a formal protest form, accompanied by a cash protest fee (protest fee may vary by region or circuit) two hundred and fifty dollars (**\$250.00**) recommended.
2. When the official protest is made with the fee, the item to be protested must be stated (a general protest will not be accepted), teardown will not be complete until protest is found to be valid or proven unwarranted. If the protest is valid, the fee will be returned to the protester. If the

protest is invalid, the fee will be given to the protested snowmobile owner for the inconvenience (to be accomplished before the snowmobiles are released from teardown).

3. There is no need for formal protests in the case of driving infractions during an event. Reports of such alleged infractions should be made to the Race Director, who in turn will request a report from the flagman or assigned official on the course.
4. Race Director has the authority to determine the validity of a protest.
5. No protests will be accepted that refer to a Race/Technical Director's judgement or decision.
6. It shall not be possible to protest or appeal technical inspection equipment, manual /electronic scoring or manual/electronic timing equipment.
7. Protests must be filed within thirty (30) minutes following the completion of the daily event or within thirty minutes following the official announcement of results for the class in question whichever occurs first. Race directors have the authority to increase the time to file a protest for a competitor but may not shorten the time allowed.
8. Properly filed protests must be addressed by sanctioning body before finalizing class results. ISR must be informed of the protest in writing immediately after the protest is filed. Electronic method of communication preferred.

APPEALS PROCESS

The following appeals process shall be applicable for all ISR affiliates and will be the binding operational guide and procedure statement for all affiliates. For any Affiliate that has an internal Appeals Process, the process will only apply to operations inside the association or company and will not have any bearing on race rule interpretation, infractions, misconduct or other situations that may arise from race activity.

TECHNICAL INFRACTIONS

Driver or team are found in non-compliance with the rules concerning fuel, sled construction, specific dimensions, materials used, or components used not conforming to the rules for each specific class, the following will be the procedure.

Tech Director or Race Director determines infraction and makes the appropriate decision considering the gravity of the offence. The Director may:

- a. Verbally warn driver or team.
- b. Disqualify driver from event for the class specified.
- c. Disqualify driver from all events entered in days competition.
- d. Fine driver, if affiliate has a fine process in place in the affiliates bylaws or published operational guide, and the fine system is published in their membership documents.
- e. Suspend driver or team for season.

ON TRACK INFRACTIONS

Race Director determines infraction and makes the appropriate decision considering the gravity of the offence. The Director may:

- a. Verbally warn driver or team.
- b. Disqualify driver from event for the class specified.
- c. Disqualify driver from all events entered in days competition.
- d. Fine driver, if affiliate has a fine process in place in the affiliates bylaws or published operational guide, and the fine system is published in their membership documents.
- e. Suspend driver or team for season.

If the affected driver feels the decision is not correct, he/she may appeal the decision in the following manner.

1. The Appeal must be presented to the affiliate Race Director in writing using the ISR approved form available from the ISR web site. This form must be presented within 30 minutes of the announcement of the disqualification or penalty. Race directors have the authority to increase the time to file a protest for a competitor but may not shorten the time allowed. The Appeal must be accepted by the affiliate.
2. The affiliate must within 24 hours convene a meeting of the owner/ management/ officials of the affiliate and review the offense/ infraction. If the offense is upheld, the driver/team can request a further appeal to ISR and ask for a review by the rules group for the discipline. ISR has 5 days to conduct such review with the rules committee of the specific discipline.
If the Appeal is found valid, all points, money, prizes, etc. are returned/ awarded to the driver/team.

3. If the offense is upheld, the Affiliate and the Driver/team must inform ISR of the situation within 24 hours of the alleged infraction. ISR will then, within 5 working days conduct a review of the situation, convene the appropriate rule review group from the proper discipline/aspect and render a decision. The decision of this session is binding and has no further appeal.

Affiliates and Drivers must review the Chain of Custody and submission of components/ fuels/ design concepts presented for the Appeal. If the driver/team does not submit samples, exhibits, photos, etc. of the offending component or fuel, the appeal is considered void and the penalty stands. If the Affiliate does not accept and submit samples, exhibits, photos, etc. of the offending component or fuel, the appeal is considered void, and the penalty is rescinded, and all prize money, awards and points are returned to the driver/team. There is no appeal of any type to this operational chain of evidence and procedure. The Operational Guideline and Appeals Forms are found here:

Race Operation Infractions [Click here](#) Rules Interpretation Issues [Click here](#) Business Operation Misconduct [Click here](#)

The affected driver/team may ask for a review of a decision or procedure within 30 minutes of the conclusion of the event or race where the infraction is deemed to have occurred.

1. The Appeal must be presented to the affiliate Race Director in writing using the ISR approved form available from the ISR web site. This form must be presented within 30 minutes of the announcement of the disqualification or penalty. Race directors have the authority to increase the time to file a protest for a competitor but may not shorten the time allowed. The Appeal must be accepted by the affiliate.
2. The affiliate must within 24 hours convene a meeting of the owner/ management/ officials of the affiliate and review the offense/ infraction. If the offense is upheld, the driver/team can request a further appeal to ISR. ISR has 5 days to conduct such review by ISR management and consultants.

If upheld the driver/team has no further appeal. If the Affiliate decision is overruled, all points, money and prizes are awarded to the driver. The ISR decision is binding and has no further appeal, from Driver/Team or Affiliate.

NOTICE

Driver infractions/ disqualifications in a drag racing, oval racing, Enduro racing, cross country racing, water cross racing, and speed run racing events will be forwarded to all ISR affiliates

NOTICE

Drivers, promoters or any personnel affiliated with ISR snowmobile events who are banned from racing or subject to other major penalties by one affiliate, having completed the hearing process, the decision shall be honored by all ISR affiliates in that discipline.

PRIZES AND AWARDS

1. All prizes, awards and paybacks shall be presented to the official winners or their appointed representatives at the close of the event, unless specifically advertised otherwise as to the time and place of awards.
2. Drivers will not be required to attend award banquets, parties, ceremonies, etc., to receive prizes, awards or pay-backs, although they are encouraged to cooperate as a courtesy to the promoter.

PIT AND PADDOCK/STAGING AREA

1. Reasonable speeds will be observed in the pit and paddock area. All pit areas are caution zones where utmost in driver awareness is required.
2. Hot pit and staging areas are limited to drivers preparing to race and their pit crewmembers. Minimum age for pit crewmembers in these areas is 14 years old. All persons in these areas must have signed a release and waiver for the event.
3. There is no minimum age for people in paddock, pit parking and cold pit areas. It is recommended that people in these areas be required to sign a release and waiver.

TESTING, TUNE-UP, WARM-UP & PRACTICE

1. Testing area must be a suitable course or area, completely free of obstructions, which provides adequate and safe run-off areas, so competitor may slow down and exit safely.
2. Officials must provide proper supervision of the testing areas as well as adequate crowd control to prevent spectators or other persons from moving onto the area.

SUPPORT VEHICLES

1. No unauthorized motorized vehicles will be allowed in the pit or staging area. Snowmobiles must return under their own power. Only disabled snowmobiles may be towed from the track.

DRIVER PROTECTIVE EQUIPMENT

It is the responsibility of the racer to select protective equipment that will conform to ISR guidelines and provide adequate protection. Even though race rules committees and ISR develop guidelines, ISR does not endorse or guarantee specific products or manufacturers of protective equipment. Racers must rely on their own judgment in the selection of helmets and other apparel for protection and durability.

1. Regardless of driver apparel passing prior inspections, compliance with the rules must be made at post-race inspections.
2. **No cameras or digital acquisition devices can be attached to any driver's helmet. This will be in effect anytime a race vehicle is on the track, whether it be a test, practice session, or in competition.**
3. ISR strongly encourages all drivers in all disciplines / divisions to source helmets that continue to display **High Vis Colors/International Orange** to prevent possible driver injuries during competitive events
4. Full coverage helmets are mandatory. Helmets will be full protective coverage and carry the 2015 Snell Foundation Approval Code. Helmets carrying European Standard ECE 22.05 are also approved. This is also mandatory in the tune-up area. The helmet must be securely fastened at all times. Helmet must display original ECE, or Snell decal as provided by the manufacturer. Decals that are covered or eliminated will be cause for rejection of the helmet. Enclosed cockpit sled drivers must use a current automotive certified helmet meeting Snell SA specification. **(NOTICE 2022-2023 Snell Approval Code will be 2020)**
5. For Oval Sprint, and Vintage oval: At least one hundred forty-four (144) square inches of visible area on both the driver's front and back (upper body) will be blaze orange in color at all events. Jackets / Pullovers / Jerseys will be teched lying flat on the ground front and back. This is strongly recommended in all other types of racing. This does not apply in Enclosed Cockpit or Outlaw 600 classes.
6. Gloves and clothing, along with at least above ankle leather boots are mandatory (above ankle boot must have a minimum of 6 inches of leather above the ankle).
7. Eye protection mandatory; facemasks may be required at the starting line at the discretion of the Race Director. If corrective lenses are required to drive a motor vehicle, the driver will also be required to wear them when racing.
8. Hearing protection is mandatory in all non-stock classes in all types of competition. Recommended for all stock class competition.
9. The use of upper body protection equipment is mandatory, except for enclosed cockpits. The upper body protection must cover all body areas shown in illustration. It will protect the driver in mid-body and back areas and be capable of resisting penetration and dissipating force of impacts while absorbing the shock of most blows. Typical motocross vests do not meet this rule.
10. Shin and knee guards are mandatory. Shin and knee guards will be worn on both legs. The shin guard must extend from the instep to above the kneecap and be constructed of an impenetrable material.
11. Upper Arm Pads and Elbow pads are highly recommended in all forms of racing.
12. Neck bracing is driver preference and is not required.

Upper Body Protection That Meets ISR Guidelines [Click Here](#)

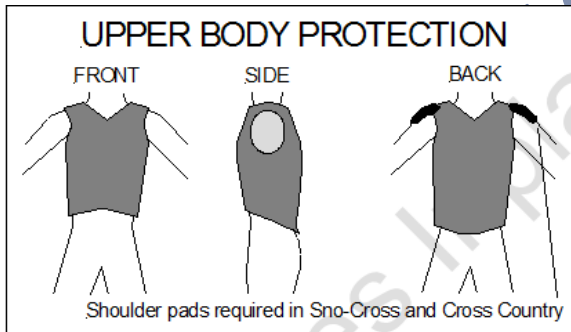

EVS [Click Here](#)

Tek Vest [Click Here](#)

Saf-Jak [Click Here](#)

Leatt Adult [Click Here](#)

Leatt Youth [Click Here](#)

HMK Protective Vest [Click Here](#)

11. Leather suits: See specific requirements in various disciplines.

GENERAL COMPETITION

FLAG RULES

1. There shall be a meeting between the flagman or his representative and corner flagmen prior to the start of a race so there is a definite understanding concerning the use of the corner flags.
2. Any competitor who does not obey the following rules will be subject to disqualification and/or fine.

GREEN FLAG

1. Start of race or signifies course is clear and race is in progress.

YELLOW FLAG

1. Displayed in track corners or along straightaway: signifies there is an additional safety hazard on the track.

RED FLAG

1. The red flag means the race will stop immediately regardless of position of snowmobiles on the track. The red flag will be used if, in the opinion of the Race Director or Chief Starter, the track is unsafe to continue the race. Snowmobiles should be brought to the starting line or pre-designated holding area if possible, using extreme caution. Snowmobiles must not leave the track proper unless directed to do so by the Race Director.

BLACK FLAG

1. On closed course races, should a vital snowmobile component such as clutch guards, ski or ski loop become dislodged or discarded, the starter upon his own recognition or being informed by track officials will display the black flag to the involved driver immediately infraction.
2. A rolled black flag is a warning to a driver that he/she may have an equipment failure or that he/she may have committed a driving infraction. Consultation flag-leave course immediately and report to the Race Director, this does not necessarily mean disqualification; however, failure to obey the rolled black flag could result in disqualification, suspension or fine. On closed course races, should a vital snowmobile component such as clutch guards, mud flaps, ski loops or ski become dislodged or discarded, the starter must display the black flag to the involved driver immediately.

WHITE FLAG

1. When displayed, drivers have started their last lap.

CHECKERED FLAG

1. When the checkered flag is displayed, it means the race is complete.

BLUE FLAG WITH YELLOW DIAGONAL

1. For passing/ this flag will be displayed to snowmobiles being lapped.

SIGNAL LIGHT RULES

1. Sanctioning bodies, which employ signal lights, must inform competitors of their signal light protocol before the start of the event. When light signals are used instead of flags, all competitors must be made aware of signal light procedures prior to the race.
2. Competitors must obey signal lights.
3. The following signals apply to OVAL closed course races:
 - a. GREEN LIGHT-Start of race.
 - b. YELLOW LIGHT-Caution
 - c. RED LIGHT- Stop snowmobile. At the direction of the Race Director, return cautiously to the starting line or designated holding area.

TIMING

1. It is the driver's responsibility to see that his snowmobile triggers the scoring system properly.

RACE STARTING PROCEDURES

1. All drivers must be assembled on the starting line, ready to race within two (2) minutes of notification of their race (except special events). This is defined as when the sleds were summoned to leave the pits. The two minute clock starts when the first sled of the group leaves the pit and enters the racecourse. All the other sleds in the event/heat/final are required to be on the line within the two- minute window.
2. Snowmobiles may be pushed to the entrance of the racecourse, once on the racecourse the snowmobile must operate under its own power.
3. All participants (including crewmembers entering the start line area, are required to wear eye protection or safety glasses.
4. Snowmobiles must be placed on an approved stand for warm-up and/ or for clearing the track. See CLEANOUT/SAFETY STANDS in this chapter.
5. All sleds in the event will need to carry repair tools and supplies on the sled. Additional safety related components may be provided to driver with race director's approval.
6. All snowmobiles on the starting line must have the track and both skis flat on the course surface, before starter begins the race.
7. All snowmobiles will be started from a standing position, in a line abreast (unless stated otherwise).
8. The driver's feet must be on the running boards or stirrups. The Race Director may disqualify a driver if the driver's method of start interferes with other contestants.

START

1. On a false start a racer will be penalized by the Chief Starter, Race Director or Flagman, and a penalty if designated will apply.
2. There shall be no change of drivers at any time without notification to the Race Director.
3. Events that take place under natural lighting will be terminated thirty (30) minutes after published sunset. This rule must be strictly enforced. Furthermore, this rule assumes that there are no other visibility issues other than sunset. If visibility is reduced beyond the prescribed limit by other factors, racing must be halted before the prescribed time.
4. Any conditions that reduce visibility (prior to 30 minutes after sunset) must be considered before continuing to race. Other conditions include (but not limited to) snow dust, ice dust, fog, haze, clouds, mist, falling snow, falling rain, and smoke.
5. It is the Race Director's responsibility to discontinue racing if the visibility falls below the prescribed level at any time during the day.
6. An injured or otherwise incapacitated driver or damaged snowmobile shall be prohibited from racing with exception that if in the Race Director's judgement, the driver or snowmobile is determined not to be a danger to driver's self or any other competitor. The Race Director's decision is final.

RACE RESTART PROCEDURE

1. The Race Director may have a restart at his discretion. Race Director's decision is final.

LEAVING THE COURSE

1. Drivers should stay on the confines of the marked course. At the discretion of the Race Director, a driver may be disqualified for leaving the confines of the course.

RACE FINISH

1. The finish line will be clearly marked.

SIGNALS

1. A driver who has spun off or stalled must raise both hands over driver's head to indicate that no more movement will be made until the field has passed and to indicate no injury.

DRIVERS BRIEFING

1. The mandatory meeting (or meetings) will be held at an announced time and place. It will be conducted by the Race Director and Race Promoter. Descriptions of the course, flags, etc. will be made. An interpreter should be used when needed. Pins, stamps, tags, roll call, random call, etc. may be used to check the identity of drivers at the briefing.

RADIOS

1. There will be no independent radio transmission on sanctioning body's radio frequency.
2. Unless otherwise stated, radio communication between crew and driver not allowed while driver is on the course.

CLEAN OUT / SAFETY STANDS

1. Snowmobile safety stands that catch and retain track, track lugs, traction components and other items that are thrown by a track are mandatory (see illustration).

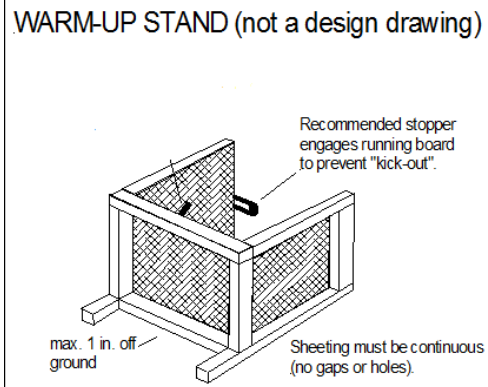

2. The stand must be no more than six (6) inches from the rear of the tunnel opening and no more than twelve (12) inches from the track. The safety stand will be constructed of metal equivalent to 6061/T6 aluminum, 1/8 inch thick. Side panels are mandatory, and they must extend at least to the center of the rear axle. Vertical coverage must be no more than one (1) inch off the ground/ice and as high as the snowmobile support device. Coverage must be continuous (no lightening holes). A plywood liner is recommended to help absorb impact. Safety stand must maintain enough height to prevent track encountering ground/ice surface. The stand must be used whenever the rear of a snowmobile is raised to clean out the engine or track.

3. No full throttle operation while snowmobile is on warm up stand.

MISUSE OF PIT PASSES

1. Improper usage of pit or paddock passes will be grounds for discipline.

FIRE EXTINGUISHER

1. Fire extinguishers must be available in pit, paddock/staging and starting line areas. Fire extinguisher minimum size will be five (5) pounds with ABC fire extinguishing capabilities. Fire extinguishers will be in place before the start of the race. All trailers, haulers, enclosed truck bodies, etc. used for transport of racing sleds and their support equipment must have 2 (two)-5-pound ABC extinguishers on board, accessible and serviceable always.

GENERAL SNOWMOBILE RULES

These **GENERAL RULES** apply to all snowmobiles in competition unless so noted. All participants, racers and crewmembers are required to be fully aware of these regulations and must abide by them.

Participants are solely responsible for the condition of their snowmobiles and their competence to operate them.

Where the rules permit or require components or equipment to be installed, replaced, altered, modified or fabricated, it is the sole responsibility of the driver to select components, materials and/or fabricate the same so that the components will perform safely in competition.

CLASS ELIGIBILITY & SNOWMOBILE ID

1. Unless otherwise specified in specific ISR rules, a snowmobile used in more than one class or division must comply with all rules and safety guidelines for each class or division in which it competes.
2. In stock and stock-based classes, the chassis and engine must have been originally OEM assembled and serial numbered indicating that the snowmobile is a stock qualified unit from the production run of a stock qualified model.
3. If the tunnel, engine or other serial numbered part is replaced, the serial number must be removed from the replaced part and affixed to the new part.

ENGINE

1. ISR and/or the Race Rules Committees will approve the validity of all engine intake systems.
2. In stock and stock-based classes, the engine must have originated from a stock qualified, OEM produced snowmobile.
3. In stock and stock-based classes, coolant thermostats, regardless of location in the cooling system, may be ran as produced, changed to alternate temperature settings, or completely removed. If removed a control plate/washer to control volume of flow may be installed in its place. This plate shall serve no other function than restricting the flow of coolant.
4. In Stock classes, the OEM for the model exhaust system must remain as produced by the manufacturer and must be fully functional. In Mod classes it will be specifically noted as to which exhaust components may be changed or modified.

5. In classes with individual chamber exhaust for each cylinder, the following minimum standards for straight-thru silencers are required:

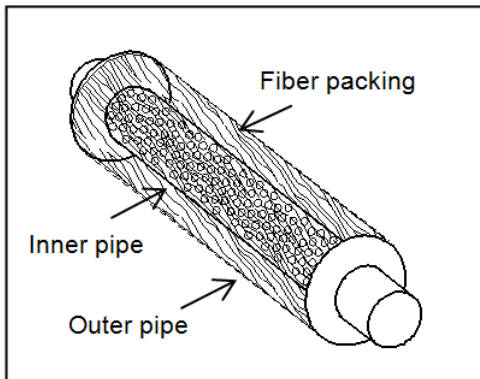

- a. Inner pipe must have at least 15 holes per square inch. Minimum hole size 1/16 in. (Minimum 3/8 in. sound absorbing material around the entire circumference of inner pipe).
- b. Inner pipe (perforated core) must contact sound absorbing material (fiber or steel wool packing).
- c. Outer pipe must be at least 3/4 in. larger than inner pipe.
- d. Minimum silencer length 3 in.

6. OEM carburetor slide valves and replacement jet components without modification will be allowed in all Stock classes. No modification to carburetor body will be allowed.
7. An adequate return spring on the throttle is required. The throttle must be a direct mechanical thumb mechanism, which must be located on the rear side (toward the rear of the snowmobile) of the right-hand handlebar. Throttle must be thumb operated. Twist grip throttles not allowed.
8. All Stock classes - Choke control devices may be disconnected; however, they may not be removed from their mounting location.

DRIVE

1. Chains, pulleys and exposed moving parts will be isolated from the driver and other competitors by shields capable of retaining all accidental explosions and component impacts.
2. Unless otherwise specified, stock class belt guards are acceptable in Stock classes only.
3. Secondary clutch windage plates may be removed in all classes. Windage plates may not be added in Stock based classes unless OEM for the model.
4. Brakes systems may be changed or altered but must always be operational. Brake components must be commercially available. Brake disc may not be relocated and must remain in stock as produced location. Liquid cooled systems allowed. Brake disk may not be modified in the pad contact areas. Brake disk hub may be modified for mounting. OEM diameter and thickness must be maintained, (Clarification) {Larger / thicker are acceptable, but not smaller / thinner. } The brake disk material may not be substituted with any other material. Aluminum and/or carbon

brake disks are not allowed.

- OEM Brake discs and pads may be replaced, if the replacement disc is OEM thickness and diameter, then brake shielding will not apply.
- Custom clutch guards, clutch guards on purpose-built chassis, and specialty chassis may use Carbon fiber, Kevlar, and other materials as reinforcement of standard clutch guard material and design. Newly designed clutch guards must exceed the specifications and limits established in standard clutch guard requirements, See specific disciplines for details. Each specific clutch guard must be submitted to ISR with digital pictures (both installed and uninstalled, at least four views) and a detailed explanation of design, design limitations, and method and type of fasteners used to affix the guard to the chassis. ISR may request an appointment to inspect on site.

SKI SUSPENSION AND STEERING

- All handlebar ends must be plugged.
- Only steel suspension springs allowed unless otherwise specified.

SKIS & SKI RUNNERS

- Except where otherwise specified, one cutting edge (steering edge) allowed per ski on snowmobiles with independent front suspension. Any ski edge with over 1/2-inch turndown constitutes a cutting edge. Hillclimb only: Ski's with over 1/2 inch *turn down on any edge will be allowed*. Multiple turn downs allowed.

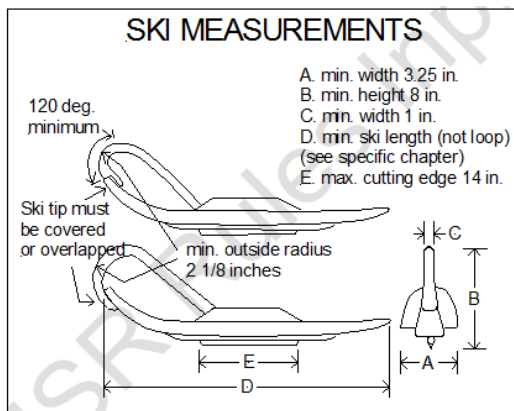

- All ski loops must be at least one (1) inch wide and 5/8-inch-thick or 1-inch diameter round material. The arc of the leading edge of the ski loop must have an outside radius of at least 2 1/8 inches and extend at least 120 degrees upward (see illustration). Plastic ski loops must be affixed with steel bolts.
- Ski tip (not including the loop) must be turned up 1.5 inch from the bottom of the ski (not including the keel(s) or ski runner).
- No part of the ski may contact the body or suspension through the ski's normal range of travel and/or movement.

TRACK SUSPENSION

- Any OEM type slide rail hyfax may be used as a replacement.
- Slide rail hyfax can be drilled in all classes.
- Where allowed in these rules and by local environmental laws, slide rail lubrication systems may be used. No lubrication medium will be allowed that hampers competitor's visibility. No toxic solutions may be used.
- Only steel suspension springs allowed unless otherwise specified.
- At safety inspection, track suspension travel will be measured vertically at the rear bumper, two inches of travel must be noted with a max 150 pounds of weight displacement.

TRACK AND TRACTION

- Track dimension rules are specified in each chapter. A 1/8-inch maximum variance in the minimum track width requirement is allowed. No cutting, notching or trimming of the track is allowed, this is class and discipline specific, and is not allowed unless preceded by an ISR Competition bulletin.
- Unless otherwise indicated, the track must be centered on the centerline of the tunnel in all modified classes. Modified classes are allowed track offset for installation of brake assembly on front driveshaft. In no case may this offset be more than 2 (two) inches, determined from edge of track to inner edge (side) of tunnel. In Stock and Stock-based classes, the track location must be as produced unless otherwise specified.
- In all forms and classes of racing, track clips and guide clips may be replaced when worn - guide clips may be removed and replaced with track clips - track clips may be removed and replaced with guide clips - the track must retain the original number of clips with which it was produced.
- In all forms of racing, there are traction device limitations, see specific chapters for details (see Appendix for traction device measurement details).
- Identification numbers affixed or molded into tracks by the molder of the track must remain completely visible and unmodified. No traction device or other item may be installed over the identification numbers on the track. Identification numbers include model number, serial number and/or any other information applied to the track by the molder.
- Tracks may not be reversed.

FRAME AND BODY

1. A rear snow flap of enough material must be installed in a permanent manner and shall be held down (restrained from rearward movement) to restrain traction components, snow, mud, rocks and other material thrown from the track at all speeds. Recommended materials are 3/16-inch fiber reinforced rubber belting or 3/16-inch semi-rigid plastic such as HD polyethylene or UHMW polyethylene.
2. The snow flap must overlap the widest part of the rear tunnel opening by at least one inch on each side.
3. The rearward movement of the snow flap must be restrained with steel cable (or similar material) to the frame of the snowmobile. The snow flap must be in contact with the course surface when the rider is on the snowmobile. Violation of this rule results in mandatory expulsion from the class.
4. Unless otherwise stated, seats in Stock class must be OEM for the model. OEM seats have no requirements for fabric, padding, dimension, or coverage. If the seat meets manufacturers legal design criteria it is legal for any class, stock or modified.
5. Unless otherwise specified, tunnel protective strips may be added to underside of tunnel to protect the tunnel and cooling system from being damaged by traction products.

IGNITION & ELECTRICAL

1. All snowmobiles must be equipped with a tether switch that must always be attached to the operator and be operable. The switch must "kill" the engine by disconnecting the ignition system when the operator and the snowmobile become separated. It is the responsibility of the driver to make certain that the tether is attached to everyone who starts the engine or operates the snowmobile.
2. Maximum tether cord length will be 4 feet except where noted otherwise. Verification of tether cord length will be determined at tether cord's fully extended length.
3. The tether cord will be securely fastened to the driver. No alligator clips allowed.
4. The tether switch will be securely mounted in a location on the snowmobile other than on the handlebars or steering column.
5. All snowmobiles must have a handlebar mounted button (on/off) kill switch on the right side within thumb reach (this is in addition to your tether switch).
6. No Wet Cell batteries allowed.

FUEL REGULATIONS

NOTICE: It is advisable for all competitors to have their fuel tested at the event, before competing.

1. A contestant appealing a fuel disqualification must bear the expense of the fuel analysis and handling.
2. Allowed gasoline and lubricants:
 - a. Only a commercially available pump gasoline that complies with these rules is allowed. (The term "pump gasoline" includes fuels dispensed from service station pumps and racing fuels that are commercially available in fuel cans and drums.) The gasoline may be mixed with petroleum, vegetable, or synthetic based lubricants. The use of oils, fuels (including gasohol), and additives that provide power-boosting characteristics are strictly forbidden.
 - b. Only motor fuel compounded of standard pump gasoline and an acceptable lubricant are allowed. Additives that produce power in excess of that produced by standard pump gasoline and petroleum base oil shall not be permitted. The list of unacceptable additives includes, but is not limited to, alcohol, nitrates, and other oxygen bearing compounds.
 - c. No competitor or driver's pit personnel shall possess power boosting additives or agents upon the race premises of the sanctioned event. Violations of this rule shall subject the violator to severe disciplinary procedure.
 - d. Aerosol cans of ether are allowed at sanctioned races for starting purposes. No driver will be allowed to carry such cans on their person or their snowmobiles during the race.
 - e. Driver statements as to their fuel components will be binding and may be verified by various fuel tests. Drivers must allow officials to test their fuel at any time.
 - f. Youth Oval Racing classes, commercially available gasoline that is reformulated with up to 10% ethanol is allowed, the exception being "Big Track" competition for 120, 206 and 200 base class sleds. 120/206/200 and all oval junior classes must use legal fuels containing no ethanol.

FUEL TESTS

WARNING: Gasoline, lubricants, additives and fuel test reagents are all potentially hazardous materials. Anyone handling them should be aware of the hazards and act accordingly. Race Rules Committees and ISR establish these guidelines and recommended test procedures, but do not assume liability for injury or death caused by the handling of these materials.

Any or all these tests may be employed. Test results may be confirmed from time to time using an infrared spectrometer.

IF ANY OF THESE FIELD TEST ARE FAILED BY A PARTIAPANT HE WILL BE DQ'ED FROM ALL CLASSES THAT HE PARTICAPATED IN FOR THAT DAY.

1. ELECTRICAL CONDUCTIVITY (DI ELECTRIC CONTENT)
2. CERIC NITRATE REAGENT TESTING
3. REAGENT D TEST FOR DIOXANE
4. WATER SOLUBILITY TESTING
5. ANY OTHER TEST APPROVED BY RACE RULES COMMITTEES

ENFORCEMENT, DISCIPLINE AND VIOLATIONS

All participants are subject to disciplinary action for violations of these rules in accordance with the sanctioning organization's bylaws. Penalties may include suspensions, fines, loss of points, disqualifications or any combination thereof. The nature of the penalty is determined by the gravity of the offense and its effect on the safety and good reputation of snowmobile racing. The violations hereinafter set forth are subject to the penalties noted.

EJECTION FROM RACE SITE

1. The Race Director has the right to eject any person(s) from the pit, paddock (staging area) or racetrack area.

CONDUCT OF PARTICIPANT (OFFICIALS, DRIVERS, CREWS, ETC.)

1. Participants are solely responsible for the condition of their snowmobiles and their competence to operate them.
2. No driver may, at any time, ride/drive in such a manner as to endanger life or limb of other riders, officials or the public.
3. Vulgarity, derogatory or offensive language will result in disciplinary action, ejection from race site and be subject to fines and penalties.
4. Any participant that threatens bodily harm or assaults any official, driver, crew, etc. will be subject to disciplinary action, ejection from race site and be subject to fines and penalties.
5. Clothing displaying vulgar language is not allowed.

DRIVER LIABILITY RELEASE COVENANT NOT TO SUE

1. *The driver/pit crew, in filing an application to enter the event, elects to use the course of the event at driver's /pit crews own risk, and thereby releases the sanctioning organization together with their heirs, assigns, officers, representatives, agents, tech personal, employees, and members, sponsoring organization and owners of properties on which sanctioned events are to be held from all liability from injury to person, property and/or reputation from tech decisions that may be received by said entrant and from all claims of said injuries to the parties listed above growing out of, or caused by any construction or condition of the course over which the event is held and or piece of equipment that participant entered into competition.*
2. *Drivers/pit crew and other participants further acknowledge and fully understand that there may also be other risks that are not known or foreseeable at this time, and the above and released persons cannot control these risks, nor have the released persons judged the participants' skill level or ability prior to allowing the participants to participate and consequently is not in a position to guarantee the participants' personal health or safety during the programs, events or activities. DRIVER/PIT CREW KNOWINGLY AND VOLUNTARILY ASSUMES ALL SUCH RISKS, BOTH KNOWN AND UNKNOWN, ANTICIPATED AND UNANTICIPATED, EVEN IF ARISING FROM THE NEGLIGENCE OF THE RELEASED PERSONS OR OTHERS, AND THE PARTICIPANTS ASSUME FULL RESPONSIBILITY AND LIABILITY FOR THE PARTICIPANTS' PARTICIPATION.*
3. *In consideration of permission and as a requirement of participation in sanctioned events, drivers, pit crew and other participants hereby covenant and agree not to sue the sanctioning organization, or its heirs, assigns, officers, representatives, agents, employees, and members, sponsoring organization and owners of properties on which sanctioned events are to be held, and further agree to fully release, indemnify and hold harmless those persons from any and all causes of action, demands, claims, and loss of injury to person or property or damages, of any nature whatsoever, whether the participation is supervised, unsupervised, however the injury is caused, including, but not limited to the negligence of any released persons.*

DRIVER RESPONSIBILITY

1. The driver has the responsibility for the actions of his crew. It is the driver's responsibility to see that all crewmembers are aware and abide by all rules and guidelines.
2. The condition of a snowmobile is the responsibility of the driver. A driver may be disciplined if driver's snowmobile is modified to defraud the officials or other competitors.

FRAUD, BRIBERY & ILLEGAL ASSISTANCE

1. In addition to non-compliance with any of the above regulations or rules, the following offenses shall be considered a breach of regulations subject to disqualification.
 - a. Bribing or attempting to bribe anyone connected with the race or accepting or offering to accept a bribe.
 - b. Competitor accepting any kind of assistance that aids in snowmobile operation during the race.
 - c. Any fraudulent proceedings or act of prejudicing the interest of the race generally.

INTOXICATING BEVERAGES & DRUGS

1. Drinking of intoxicating beverages is strictly forbidden by any participant. Anyone showing evidence of having used an intoxicating beverage must leave the premises (specifically pit, paddock (staging area), warm up area, tear down and race track) immediately and be subject to disciplinary action by the disciplinary committee. This shall be in effect through the final inspection of snowmobiles.
2. Possession or use of illegal drugs or drug substances, as defined below, is prohibited in any form, by any participant, on the race facility, or in

- any area considered to be used in the operation of the race facility, such as parking lots or leased properties.
3. Illegal drugs are these substances defined and prohibited by state/provincial and/or federal law.
 4. Any person found to be in possession or under the influence of an illegal drug or drug substance on race facility property, as defined above, or any person who is arrested by duly constituted authorities and charged with possession and/or use of illegal drugs or drug substance or any person who is formally charged by a court of law with illegal drug violations, shall be subject to suspension from competition and eviction from the race facility, and denial of further entry to the race facility for a period determined by the disciplinary committee.
 5. Any participant who is formally charged by a court of law with an illegal drug violation, upon notification to the ISR Advisory Board, shall be suspended from all forms of participation at any ISR event until such time as the charges are fully adjudicated through the legal process. Any conviction of a formal drug charge by such will be prohibited from taking part in any ISR or affiliated event for a minimum period of three (3) years from date of conviction.
 6. Any participant suspended for violation of these rules may be granted an appeal hearing by a board of officials designated by the ISR Advisory Board, provided the suspended participant requests such hearing in writing, within fourteen (14) calendar days of the date of suspension. It is the responsibility of the suspended party to make such a request if a hearing is desired.
 7. The cost of convening the board of officials will be borne by the participant prior to the convening of the board.
 8. A participant suspended for violation of these rules, EXCEPT IN THE CASE OF PERSONS CHARGED WITH SELLING DRUGS, may, as the result of a decision reached through the hearing process detailed above, be reinstated, if it is mutually agreed that the participant (at his own expense) will produce documentation from a physician licensed within the state or province, certifying that he or she is drug independent, as a result of random and periodical examinations and urinalysis testing made at the request of the ISR Advisory Board.
 9. If a participant is using prescription drugs on advice of a physician, such use must be reported to the Race Director prior to the participant's entry into any ISR activities. Failure to notify will subject the participant to penalties as prescribed above.
 10. A participant is any person taking part in any event sanctioned by or affiliated with International Snowmobile Racing, Inc., in any form, including but not restricted to drivers, snowmobile owners, mechanics, crew members, sponsors, track officials, pit area personnel, manufacturers and press representatives. All such persons shall be considered public figures that have by their own choice become involved in the snowmobile racing events, with the full understanding that he or she must abide by the rules and regulations established and published by ISR. All participants are responsible for their personal conduct.

RACE DIRECTOR AUTHORITY

1. The Race Director and Technical Director will be certified by the sanctioning organization.
2. The Race Director shall be responsible for the conduct of the race. He shall have the right to make the final determination concerning all aspects of the race and the race facility, including design (these rules and regulations notwithstanding). **The Race Director is defined as the overseer/controller of the actual track operations during an event. He has prevue over all aspects of the race and interpreting rules that are applied. He may be a track owner/ or contract manager of a facility, however, "Race Directors" that are of administrative or business side of the event, although they may be referred to as race directors are not the on track event director. In any case ISR certification is required.**
3. He shall have the voice of authority to discipline the participants for violation of the rules. Such discipline will be limited to disqualification of a participant and/or exclusion from an event.
4. Official race results shall be approved by the assigned Race Director and a signed copy will be returned to the promoter for announcement and distribution.
5. Race Director may not have vested interest in the outcome of an event over which he/she officiates. He/she may not officiate over a class in which he/she has a vested interest.
6. Race Directors may compete in events other than those in which they officiate.
7. The Race Director may cancel any race or the complete event for reasons of safety regarding competitors or spectators, and in such case shall determine the awards, if any. The Race Director may shorten the race for any reasons of safety but must give drivers adequate notice in advance.
8. A Race Director may judge the mechanical integrity of all timing equipment.
9. Only Drivers (no other participants) will have discussions with the Race Director about protests, and driving complaints, etc., and may approach the Director before the day's events, after an event, or at the direction of the Race Director.
10. The Race Director has the authority to judge the racing abilities of competitors and take appropriate action to insure the safety of the event.
11. The Race/Tech director shall have the authority to determine structural integrity.
12. The Technical Director shall carry and be responsible for the official specifications and certain instruments for measurements concerning verification and control of contestants' snowmobiles. The Technical Director may not officiate over a class in which he has a vested interest.
13. Technical equipment and specifications will not be used for any purpose other than the conduct of the sanctioned event.
14. Decisions of the Race/Tech Director may be reviewed by the board of the sanctioning body.
15. Decisions made at an event shall not be overturned without a formal appeal. Notice of the appeal process shall be given and a suitable period for all parties to prepare must be allowed.

NO EXPRESS OR IMPLIED WARRANTY OF SAFETY SHALL RESULT FROM PUBLICATION OF OR COMPLIANCE WITH THE RULES AND REGULATIONS IN THIS PUBLICATION. THEY ARE INTENDED AS A GUIDE FOR THE CONDUCT OF THE SPORT AND ARE IN NO WAY A GUARANTEE AGAINST INJURY OR DEATH TO SPECTATORS OR PARTICIPANTS

MOUNTAIN CROSS COMPETITION

Mountain Cross competition is conducted on a hill climb slope with two snowmobiles racing to the finish line at the top on two separate but parallel courses. The two courses are marked with "gates". Drivers must pass through all the "gates" on their course.

DIVISIONS, CLASSES AND FORMAT

The intent of these classes is to establish races in which all can compete at their level of personal and equipment ability. The class structure is organized in such a way as to enable as many snowmobiles as possible a place to successfully compete.

If class rules are not followed, the class name shall not be used, and the class shall be run as a specialty class with ISR's prior approval.

DRIVER DIVISIONS

Pro
Semi Pro
Amateur
Juniors
Women's
Masters

STOCK CLASSES

Stock 600 (600cc maximum)
Stock 700 (700cc maximum)
Stock 800 (800cc maximum)
Stock 900 (900cc maximum)
Stock 1000 (1000cc maximum)
Pro Masters Stock 800 (min. driver age is 40)

IMPROVED STOCK CLASSES

Improved Stock 600 (600cc maximum)
Improved Stock 700 (700cc maximum)
Improved Stock 800 (800cc maximum)
Improved Stock 1000 (1000cc maximum)
Pro Masters Improved Stock 1000 (min. age is 40)

MODIFIED CLASSES

Mod 600 (600cc maximum)
Mod 700 (700cc maximum)
Mod 800 (800cc maximum)
Mod 1500 (1500cc maximum)

NOTE: In order to run the Mod 1500 class, the top of the hill must be at least 4000 feet in elevation.

Pro Masters Mod 1500 (min. driver age is 40)

SPECIALTY CLASSES

1. SEMI PRO DIVISION
 - Semi Pro Stock 800 (800cc maximum)
 - Semi Pro Open 800 (800cc maximum)
2. WOMENS DIVISION
 - Women's Stock 700 (700cc maximum)
 - Women's Open 800 (800cc maximum)
3. Any specialty classes that meet specified safety standards can be raced in Mountain-cross events.
4. A special sanction can be any snowmobile Mountain Cross event that does not fall under any of the specific circuits or classes but meets the established safety standards.
5. All special sanctions and specialty classes must be approved in writing by ISR and the rules committee before competition.

FORMAT

The following rules govern the conduct of ISR Mountain Cross events. The format may vary according to the region, hill conditions and promoter preference, but all such variations should be advertised for the information and convenience of competitors. Alternate formats will be allowed at the discretion of the ISR affiliate with the preapproval of ISR. The alternate format cannot contradict the basic format for ISR Mountain Cross competition.

STANDARD MOUNTAIN-CROSS FORMAT

1. A Mountain Cross event shall be conducted on a snow-covered slope. The event area shall be set-up according to ISR guidelines. (See the Recommended Hill climb Course Layout in the Appendix.)
2. Two side-by-side courses shall be marked off with "gates". Each "gate" shall consist of two flexible marker poles adjacent to each other through which the snowmobile must pass. The two courses shall be near each other but not so close as to promote contact between the two snowmobiles.
3. The event shall consist of several races in which two snowmobiles will compete side-by-side up the slope. The driver must go through each gate on his/her course. Gate poles may be hit but must not be knocked down or broken off.
4. The winner of each race shall be the driver who reaches the finish line first or, in the case that neither reaches the finish line, the driver and snowmobile (as a unit) attaining the highest mark shall be the winner.
5. Each competitor shall compete on each course to determine results. At the discretion of the sanctioning body, the two runs may be added together, or the best run scored.

ORDER OF CLASSES

1. Order of classes to be run will be determined by the Promoter and properly posted for the convenience of the competitors.

GENERAL COMPETITION RULES

1. Unless otherwise specified, Mountain-Cross rules are the same as Hill climb rules.

STOCK CLASS RULES

DRIVE

1. OEM for the model clutches must be used. OEM or aftermarket roller helix allowed in the secondary clutch.
2. On snowmobiles that comply, in all respects, with the Stock class rules, the OEM belt guard may be used when moving up to Improved Stock or Modified classes.

SKIS SUSPENSION AND STEERING

1. Any sway bar allowed. No modification allowed to chassis or suspension to facilitate sway bar installation. Sway bar may be disconnected or removed. If disconnected and not removed, all remaining components must be secured so as not to endanger driver or other drivers.
2. Any commercially available handlebars may be used. Handlebars must have OEM type padding. Throttle and brake controls must remain in OEM position. Only one throttle lever allowed.
3. No modification to steering column allowed.

SKIS AND SKI RUNNERS

1. Commercially available aftermarket or OEM skis allowed. Multi-keel skis allowed.
2. Any sharp cutting edge (of any material) must be at least 1-1/4 inches from outside, bottom edge of ski board.
3. Ski runners on outside edge of ski must be unsharpened, round section with no cutting edge.

TRACK SUSPENSION

1. Any commercially available one-piece molded rubber track may be used. Maximum lug height is 2 inches. Unless otherwise specified, no modification to chassis, suspension or drive to facilitate track installation is allowed.
2. Any track drive sprocket within the brand may be used.
3. Metal rear axle idler wheels may be used.

TRACK AND TRACTION

4. Any commercially available one-piece molded rubber track may be used. Maximum lug height is 2 inches. Unless otherwise specified, no modification to chassis, suspension or drive to facilitate track installation is allowed.

FRAME AND BODY

1. Snow flap must conform to GENERAL RULES AND REGULATIONS.

IMPROVED STOCK RULES

GENERAL

1. Snowmobile must be an ISR Stock Qualified model. All sleds must comply with GENERAL RULES AND REGULATIONS section.
2. Any alterations allowed in Stock are allowed in Improved Stock.
3. The sled must have original OEM for the model or factory designated replacement engine, frame and fuel tank.
4. A full-bodied snowmobile that conforms to Improved Stock rules may advance to Modified with the Improved Stock clutch cover.

ENGINE

1. Crankcase, crankshaft and cylinders must be OEM for the model.
2. Modifications allowed in Improved Stock Hill climb are allowed.
3. Aftermarket cylinder heads allowed.
4. Carburetors may be changed.

DRIVE

1. Clutch cover must conform to rules for Improved Stock clutch cover in Hill climb.
2. Chain case must be OEM for the model and remain in OEM location.

SKI SUSPENSION AND STEERING

1. Suspension parts may be replaced. Must retain OEM Stock Appearance.

TRACK SUSPENSION

1. Suspension parts may be replaced. Must retain OEM Stock Appearance.

TRACK AND TRACTION

1. Improved Stock Hill climb rules apply except that maximum height of track lugs and traction device is 2 1/4 inches measured from the flat of the track.

FRAME AND BODY

1. OEM for the model bulkhead must be maintained. Aftermarket rear tunnel allowed. Tunnel must extend, uninterrupted, to the snow flap. Must be stock appearing.
2. Aftermarket hoods allowed. Must be Stock Appearing. Hood must have OEM for the model decals.
3. Aftermarket seats allowed. Must be Stock Appearing.
4. Fuel tank must be OEM for the model. The OEM fuel tank is the only tank that can be used for fuel supply. Lubricating tank may not be used as fuel tank.

IGNITION AND ELECTRICAL

1. Magneto and ignition system must be OEM for the model (except for spark plugs).

MODIFIED CLASS RULES

GENERAL

1. Modifications or alterations allowed in Stock and Improved Stock are allowed in modified.

ENGINE

1. Any functionally silenced exhaust system allowed.

DRIVE

1. Clutch cover must conform to rules for Modified class clutch cover in Hill climb.

FRAME AND BODY

1. Modified class snowmobiles may run without a hood.